

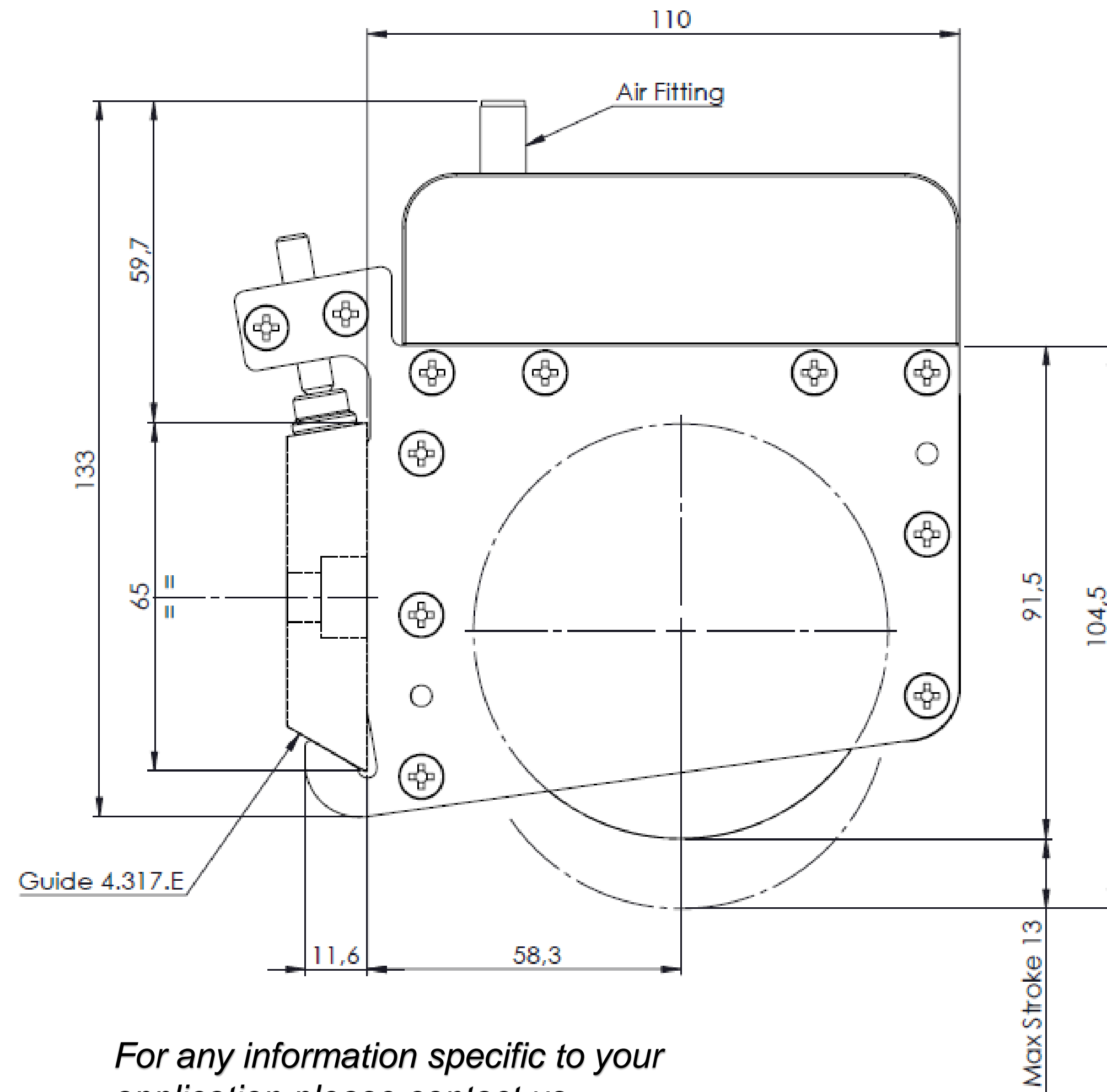

EK-12 Crush cutting knifeholders

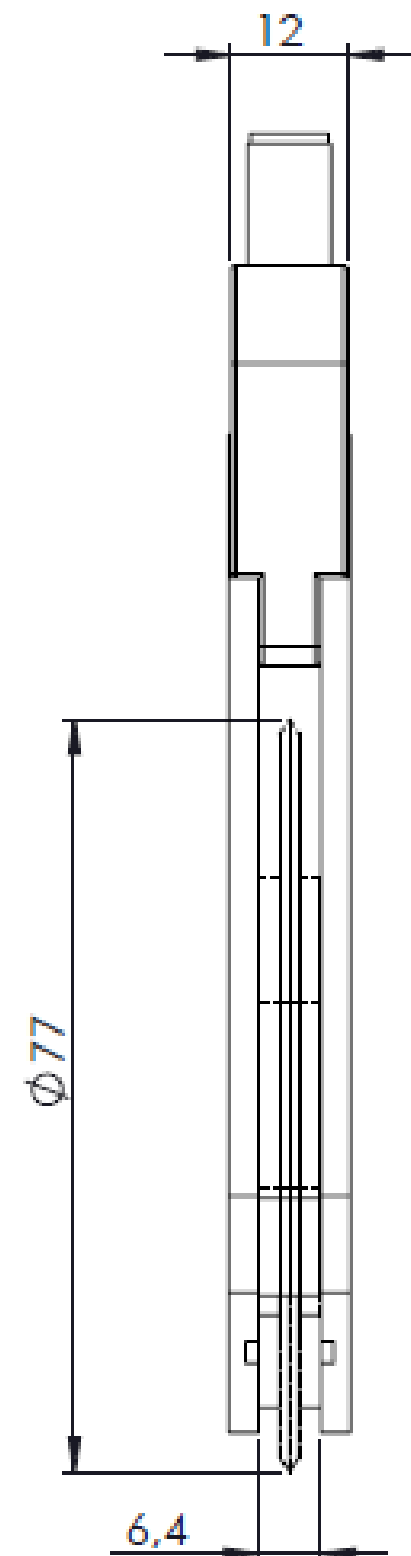

For any information specific to your application please contact us

Min. slit	12 mm
Blade stroke, max	13 mm
Pressure at 6Bar	30 kg

Indicative values, for alternative materials ask for our evaluation

Usually, to have more benefits, blade longer life and higher cut quality, we suggest to install a shear cut solution